

# Instructions

## Kit Number: KBT46

use with ID200, ID250 and NME454, NME654 or NME954

### Includes:

Description	Qty.
Cover, Gray	1
Lid Assembly	1
Bracket	2
8 Screw	12
RTV	1
Label	1
Installation Instructions	1
Acorn Nut, 8-32 Nylon	2
Sealing Washer	2
Baffle, Ice	1
8 Nylon Washer	2
Insulation Strip	1
Ice Diverter Kit	1

1. Unpack kit.
2. Insert a baffle assembly into the adapter lid.
3. Place two sealing washers (item 9) over studs and (2) flat washers (item 11), then fasten in place with (2) plastic acorn nuts (item 8).
4. Set ice maker lid on the top of the dispenser.
5. Using the slotted holes in the lid as a template, drill 4 .140" diameter (9/64") holes at the bottom of the slots (see detail A). Use extreme care not to drill into the hopper. Fasten the lid to the dispenser with four (4) #8 sheet metal screws, two on each side.
6. Seal the ice maker to the top of the dispenser as follows:
  - A. Run beads of RTV around the opening in the lid and inside the perimeter of the ice maker outline so that the ice maker will set on the RTV.
  - B. Set the ice maker onto the lid and position it as required.
  - C. Wipe away the excess RTV.

7. Drill  $9/64$ " diameter holes into the ice maker cabinet using the bracket as a template. Use extreme care not to drill into any ice maker components (condenser, tubing, etc.). Secure the brackets using the screws provided.

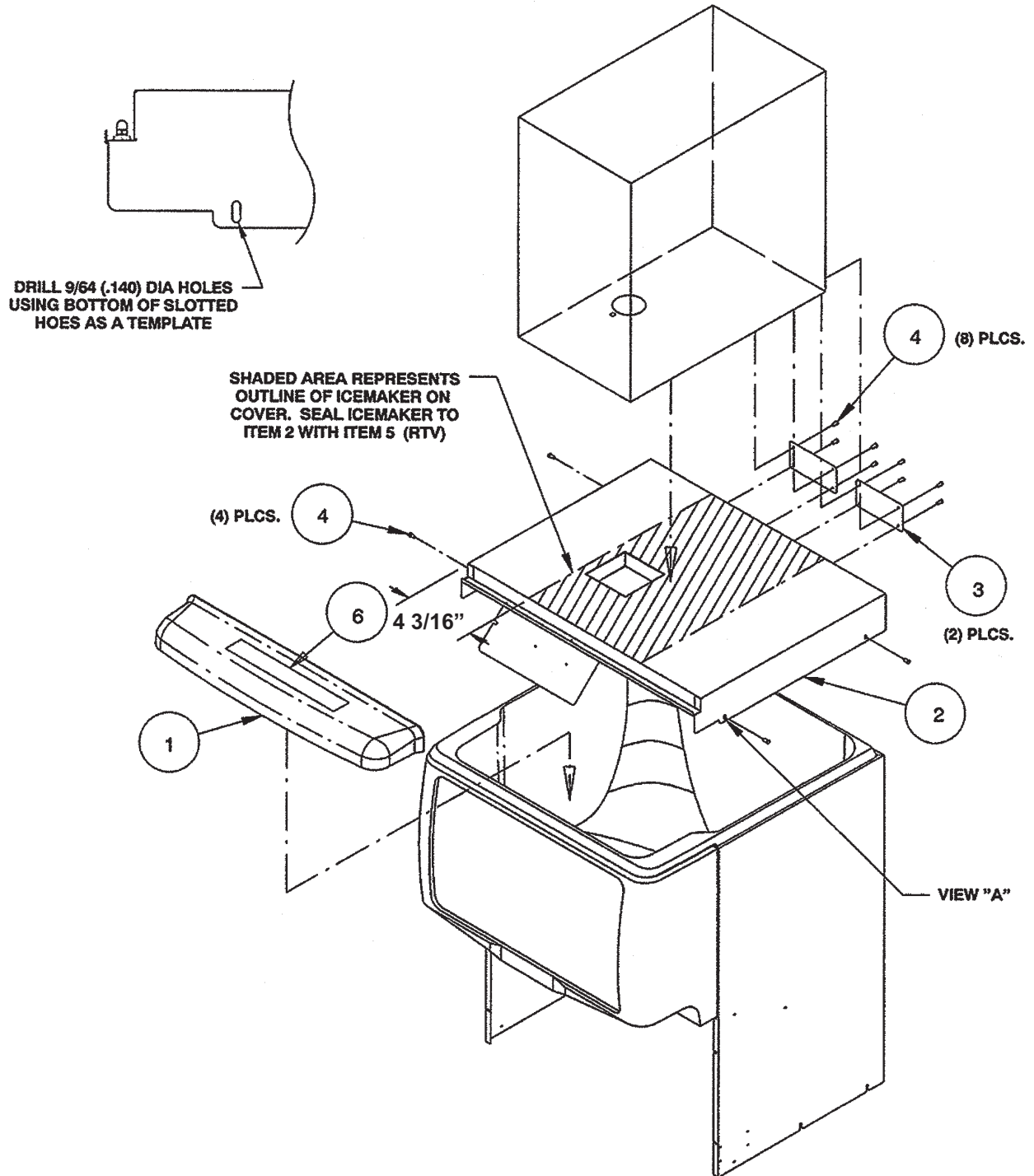

9. Follow the directions in the ice machine's manual for installation.

10. If the plastic acorn nuts interfere with the positioning of the plastic manual fill cover, it may be necessary to make small notches in the back flange of the cover to clear the acorn nuts.

